



LIEBHERR LTM1200-5.1 (250T)



EQUIPMENT SPECIFICATIONS



**WITHOUT
QUESTION**

WWW.IRVINGEQUIPMENT.COM



WITHOUT QUESTION

IRVING EQUIPMENT LIMITED
 1-800-561-CRANE (2726)
WWW.IRVINGEQUIPMENT.COM

INFO

IDENTIFICATION

Asset Number	CR299
Crane Make	Liebherr
Crane Model	LTM1200 – 5.1
Type	250T All-Terrain

Serial Number 093771

DIMENSIONS

Overall length of carrier	43'8"
Overall width of carrier	10'2"
Transportation height	13'1"
Fullspan outriggers c-c	27'3"
Midspan outriggers c-c	20'5"
Outriggers, front to rear length	29'2"
Tailswing radius	17'11" – 22'6"
Overall length, boom in rest.	50'2"
Center of rotation to back bumper	13'11"
Center of rotation to front bumper	29'8"
Weight, counterweight removed	132,000lbs

Dolly 3 Axle

FEATURES

- LICCON 2 System
- Long-reach 236' main boom, plus bi-fold jib & inserts
- 5-Axle machine allows great on-site maneuverability
- 18' Jib ideal for self-tailing operations (eliminates tailing crane)
- Vario-base outrigger system allows flexibility on confined job sites

HOISTING INFO

Full counterweight	158,800lb
Fixed jib, length options	17.7' – 118.1'
Fixed jib, offset angles	0°, 22.5°, 45°
Luffing jib	Live, hydraulic
Main boom max. length	236'
Slewing speed	1.3 rpm
Boom up time to 1-82°	50 seconds
Travel Speed	80km/h
Boom scoping time 43'-236'	580 seconds
Hook blocks	Ball and 1, 3, or 5-Sheave
Line Pull, max. single line	23,600lbs
Max line speed	426ft/minute
Gradeability	55.4%
Hoist rope diameter	23mm





WITHOUT QUESTION

IRVING EQUIPMENT LIMITED
 1-800-561-CRANE (2726)
WWW.IRVINGEQUIPMENT.COM

RANGE – MAIN BOOM

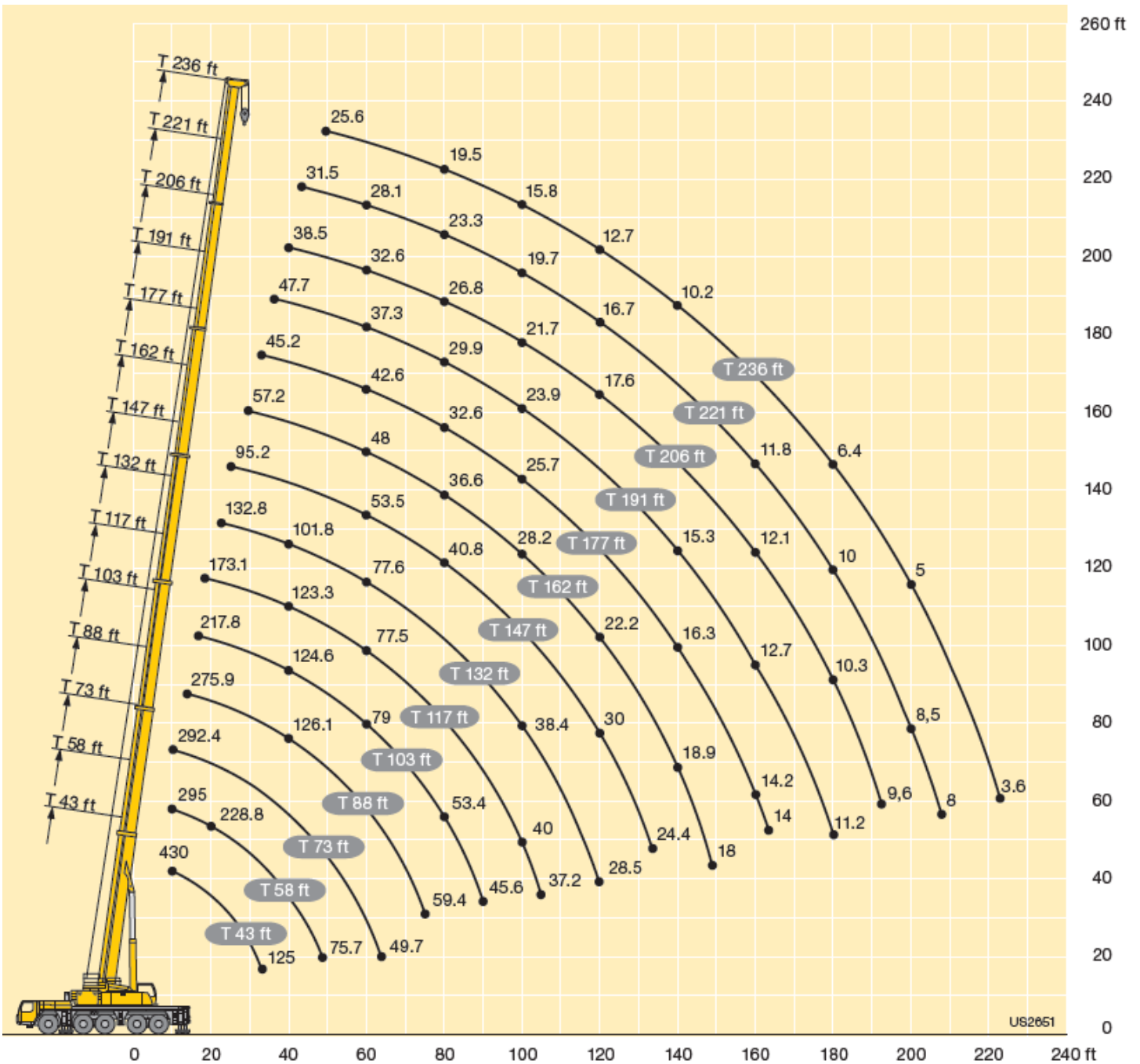

US2651



WITHOUT QUESTION

IRVING EQUIPMENT LIMITED
 1-800-561-CRANE (2726)
WWW.IRVINGEQUIPMENT.COM

CAPACITIES

Lifting capacities
Forces de levage

T



ft														ft		
	43 ft	58 ft	73 ft	88 ft	103 ft	117 ft	132 ft	147 ft	162 ft	177 ft	191 ft	206 ft	221 ft		236 ft	
10	430	295	295	292.4												10
11	314.3	295	295	293.3												11
12	311.6	295	295	291.9	275.9											12
13	295.2	295	294.4	289	273.8											13
14	283.3	288	288.8	281.1	271.5											14
15	272.5	277	276.1	267.2	258.7	217.8										15
16	259.8	265.5	263.1	252	245	216.6										16
17	255.3	255	254.1	243	236.7	215.4										17
18	247.3	245.2	245.1	234.6	228.8	214.2										18
19	238	236.1	236.1	226.8	221.2	213	173.1									19
20	229.2	227.5	228.8	219.6	213.8	206.8	172									20
22	213	211.9	213.3	206.8	200.8	194.5	169.7	132.8								22
24	198.6	197.9	199.4	195.2	189.4	183.1	167.2	129.6								24
26	180.9	185.5	186.9	184.7	179.3	173	161.9	126.5	95.2							26
28	168.9	174.4	175.7	174.3	170.4	164	156.1	123.3	92.5	57.2						28
30	160.9	164.4	165.8	164.2	162.3	155.9	150.3	119.8	89.8	75						30
32	144.8	155.4	158.8	155.1	154.9	148.8	144.5	116.1	87.1	73	45.2					32
34	125	138.2	148.2	146.6	147.9	142	138.7	112.5	84.3	70.9	59.6					34
36			140.3	138.7	140.2	136.2	133.8	108.9	81.4	68.9	58.3	47.7				36
38			133.1	131.5	133	130.3	128.5	105.2	78.8	66.9	57.1	46.9				38
40			126.4	124.6	126.1	124.6	123.3	101.8	75.7	65	55.8	46.1	38.5			40
45			110.8	111.3	110.6	109.4	111.2	95	68.8	60.2	52.5	44	37.1	31.5		45
50			75.7	98.1	97.4	98.2	97.9	88.6	63.5	55.4	49.1	41.8	35.6	30.4	25.6	50
55				87.1	86.3	88.2	86.8	82.8	58.5	51.5	45.6	39.5	34.1	29.3	24.6	55
60				77.9	77	79	77.5	77.6	53.5	48	42.6	37.3	32.6	28.1	23.6	60
65				49.7	69.1	71	69.5	70.9	49.8	44.6	39.9	35.2	31.1	26.9	22.6	65
70					64.1	64.2	64.5	64.4	46.7	41.3	37.4	33.3	29.6	25.7	21.6	70
75					59.4	58.4	60.3	58.8	43.5	38.8	34.8	31.6	28.1	24.5	20.5	75
80						53.4	55.2	53.7	40.8	36.6	32.6	29.9	26.8	23.3	19.5	80
85						48.9	50.7	49.1	38.8	34.3	30.8	28.2	25.4	22.4	18.5	85
90							45.6	46.7	45.1	37.3	32	29.1	26.7	24.1	17.6	90
95								43.1	41.6	35.9	29.6	27.4	25.3	22.8	16.7	95
100								40	38.4	34.5	28.2	25.7	23.9	21.7	15.8	100
105								37.2	35.6	33.1	28.6	24	22.5	20.7	15	105
110									33.1	32.1	25	22.7	21.1	19.7	14.1	110
115									30.7	31.2	23.4	21.5	19.8	18.6	13.4	115
120									28.5	30	22.2	20.4	18.8	17.6	12.7	120
125										27.9	21.3	19.2	17.9	16.7	12.1	125
130										26.1	20.3	18	17	15.9	11.5	130
135										24.4	19.5	17.2	16.2	15.2	10.9	135
140											18.9	16.3	15.3	14.5	10.2	140
145											18.4	15.6	14.6	13.9	9.6	145
150											18	14.9	13.9	13.3	9.1	150
155												14.5	13.3	12.6	8.6	155
160												14.2	12.7	12.1	8.2	160
165												14	12.2	11.6	7.7	165
170													11.8	11.2	7.3	170
175													11.4	10.7	6.8	175
180													11.2	10.3	6.4	180
185														10	6	185
190														9.7	5.7	190
195														9.6	5.3	195
200															8.5	200
205															8.2	205
210															8	210
215															4	215
220															3.8	220
225															3.6	225

* over rear - en arrière



**WITHOUT
QUESTION**

IRVING EQUIPMENT LIMITED
 1-800-561-CRANE (2726)
 WWW.IRVINGEQUIPMENT.COM

RANGE - JIB

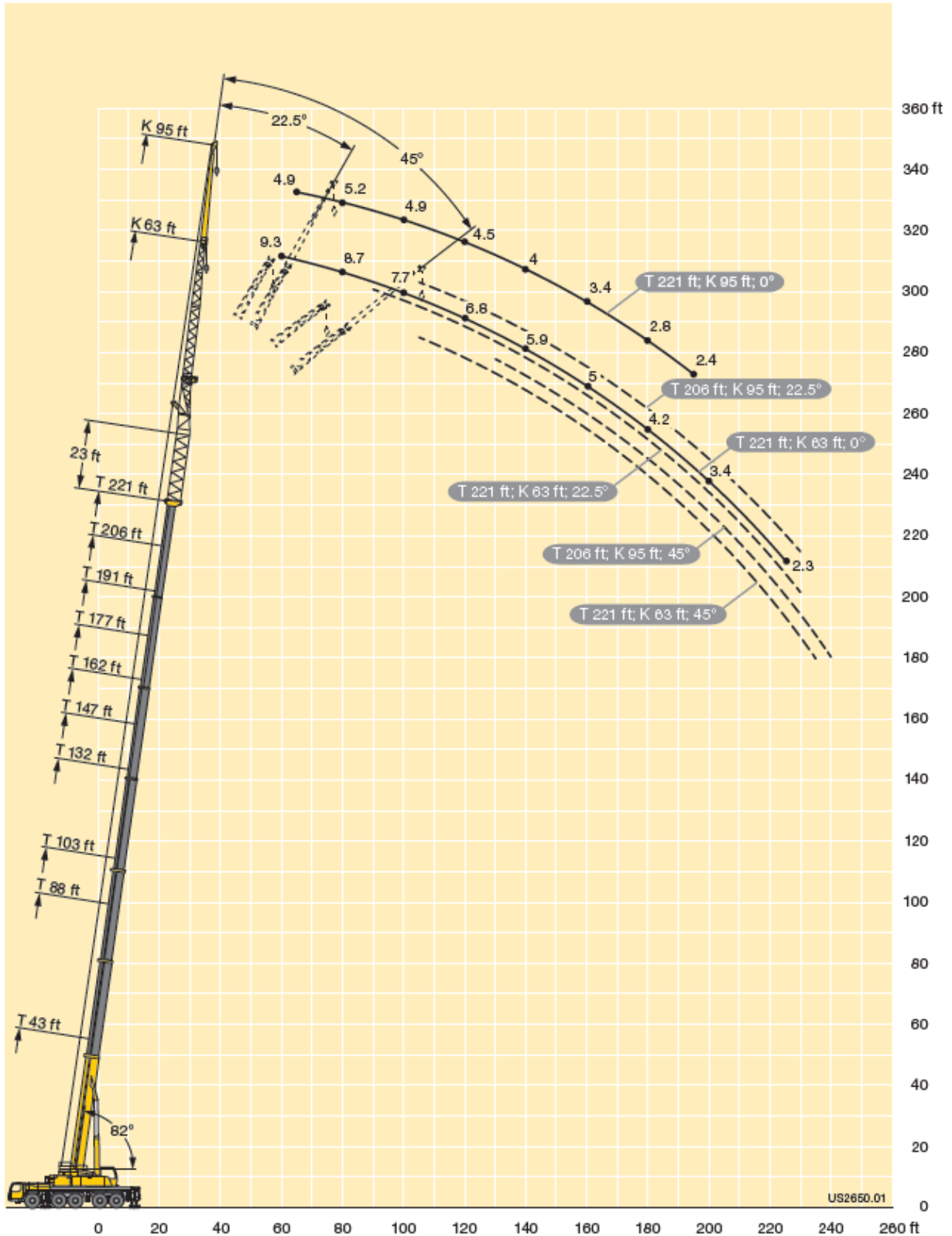



WITHOUT QUESTION

IRVING EQUIPMENT LIMITED
 1-800-561-CRANE (2726)
WWW.IRVINGEQUIPMENT.COM

CAPACITIES

Lifting capacities
Forces de levage

TVK

LICCON2



ft	177 ft + 23 ft			191 ft + 23 ft			206 ft + 23 ft			221 + 23 ft	ft
	95 ft			95 ft			95 ft			95 ft	
	0°	22.5°	45°	0°	22.5°	45°	0°	22.5°	45°	0°	
55	10.6										55
60	10.6			9.3							60
65	10.5			9.2			7.5			4.9	65
70	10.5			9			7.4			5	70
75	10.4			8.9			7.3			5.1	75
80	10.3			8.8			7.3			5.2	80
85	10.1			8.7			7.2			5.2	85
90	10			8.7			7.1			5.1	90
95	9.8	8.5		8.6			6.9			5	95
100	9.6	8.3		8.5	7.8		6.8			4.9	100
105	9.4	8		8.4	7.6		6.7	6.6		4.8	105
110	9.2	7.7		8.4	7.4		6.5	6.5		4.7	110
115	9	7.5		8.3	7.2		6.4	6.4		4.6	115
120	8.7	7.3	6.6	8.1	7		6.2	6.3		4.5	120
125	8.4	7.1	6.4	7.8	6.8	6.2	6.1	6.1		4.4	125
130	8.1	6.9	6.3	7.6	6.6	6	5.9	5.9	5.4	4.3	130
135	7.9	6.7	6.1	7.4	6.5	5.9	5.7	5.7	5.3	4.2	135
140	7.6	6.6	6	7.1	6.3	5.8	5.5	5.5	5.2	4	140
145	7.4	6.4	5.8	6.8	6.1	5.7	5.3	5.3	5.2	3.9	145
150	7.2	6.2	5.7	6.6	6	5.6	5.1	5.2	5.1	3.7	150
155	7	6	5.6	6.3	5.8	5.4	4.9	5	5	3.6	155
160	6.8	5.9	5.5	6.1	5.7	5.3	4.7	4.8	4.9	3.4	160
165	6.6	5.7	5.4	5.8	5.6	5.2	4.5	4.6	4.8	3.3	165
170	6.4	5.6	5.2	5.6	5.4	5.1	4.3	4.4	4.7	3.1	170
175	6.2	5.4	5.1	5.3	5.3	5.1	4.1	4.3	4.5	3	175
180	6	5.3	5	5.1	5.1	5	3.9	4.1	4.4	2.8	180
185	5.8	5.2	5	4.8	4.9	4.9	3.7	3.9	4.2	2.7	185
190	5.6	5.1	4.9	4.6	4.8	4.8	3.5	3.8	4.1	2.5	190
195	5.3	4.9	4.8	4.3	4.6	4.7	3.3	3.6	3.9	2.4	195
200	5	4.8	4.7	4	4.4	4.6	3.1	3.4	3.7		200
205	4.8	4.7	4.6	3.8	4.2	4.5	2.9	3.3	3.6		205
210	4.5	4.5	4.6	3.5	4.1	4.4	2.8	3.1	3.4		210
215	4.2	4.3	4.5	3.3	3.9	4.3	2.6	2.9	3.2		215
220	3.9	4.1	4.4	3	3.7	4.1	2.3	2.8	3.1		220
225	3.6	4	4.3	2.8	3.4	3.8		2.6	2.9		225
230	3.3	3.8	4.2	2.5	3.1	3.5		2.4	2.7		230
235	3.1	3.6	3.9	2.2	2.9	3.1			2.5		235
240	2.9	3.4	3.5		2.6	2.8			2.2		240
245	2.6	3.1	3.2		2.3	2.5					245
250	2.4	2.8	2.8			2.2					250
255		2.5	2.5								255
260		2.2									260



WITHOUT QUESTION

IRVING EQUIPMENT LIMITED
1-800-561-CRANE (2726)
WWW.IRVINGEQUIPMENT.COM

KEY DIMENSIONS

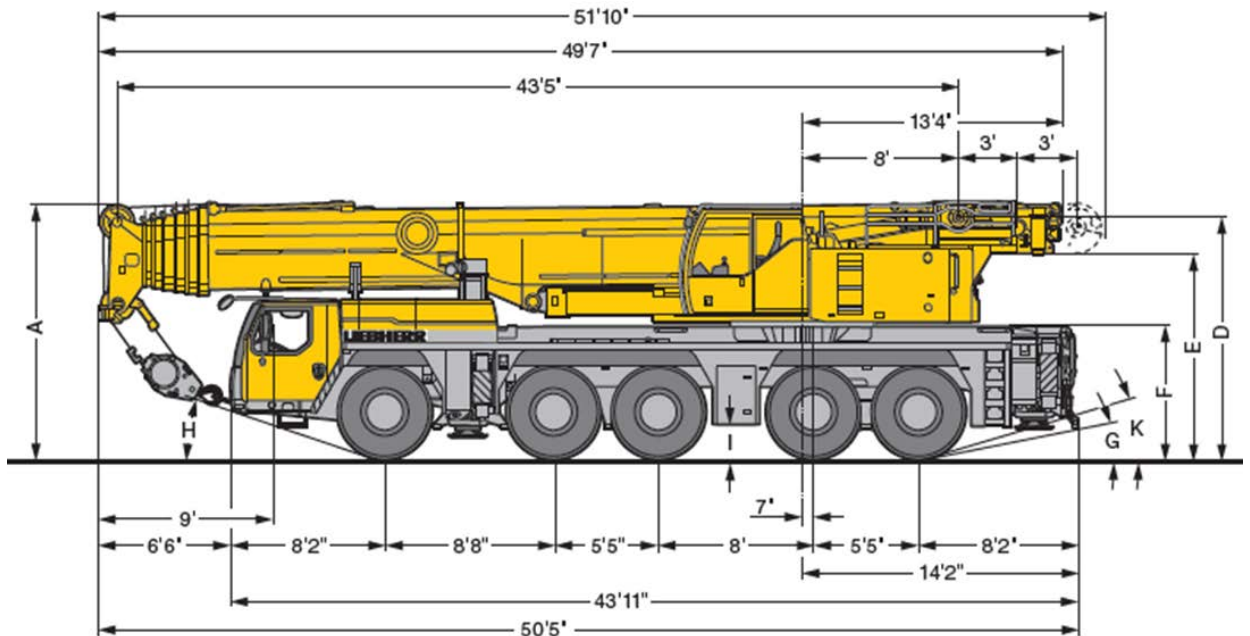
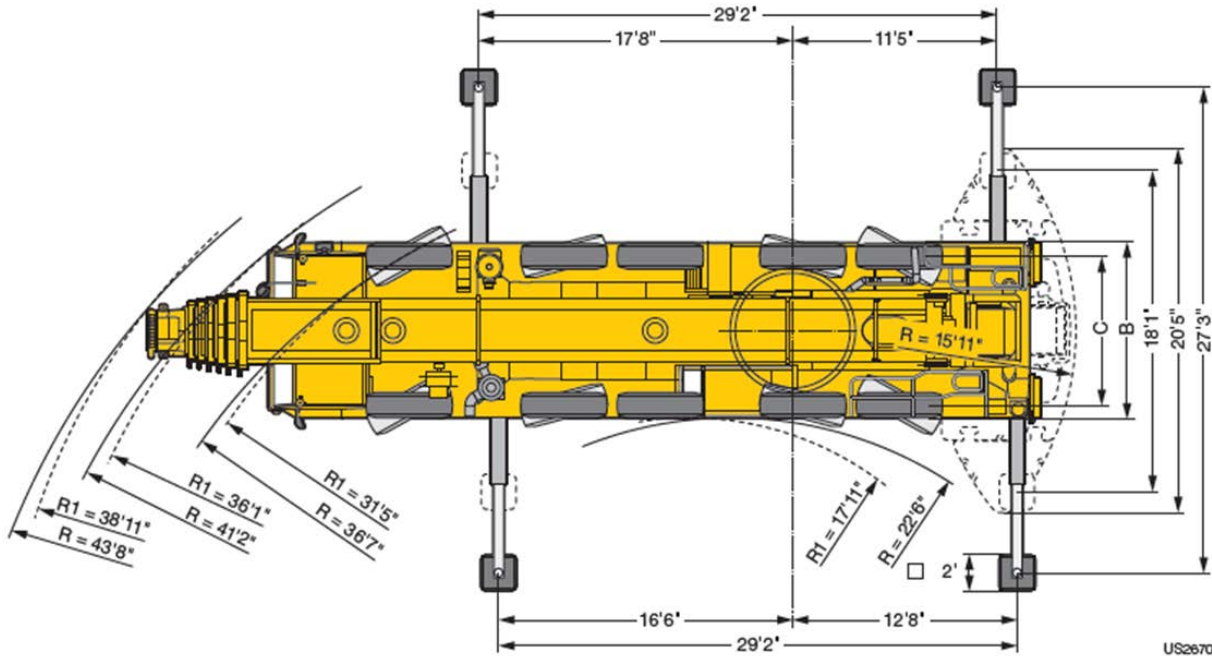

- ✓ FULL-SERVICE PROVIDER FOR CRANE RENTAL, RIGGING, AND LIFT PLANNING.
- ✓ DAILY, WEEKLY, MONTHLY RATES AVAILABLE
- ✓ DRY-LEASE AND LONG-TERM RENTALS
- ✓ OUR PURPOSE IS TO LEAVE 'NO ROOM FOR DOUBT'!